

AVERY DENNISON MARKETING SPECIFICATION

HISTORY

REV.	DATE	DESCRIPTION
A	06-23-14	RELEASED

THE SUBJECT MATTER DISCLOSED HEREIN EMBODIES PROPRIETARY INFORMATION WHICH IS THE CONFIDENTIAL PROPERTY OF THE AVERY DENNISON CO. NONE OF WHICH SHALL BE COPIED, REPRODUCED, DISCLOSED TO OTHERS, PUBLISHED OR USED IN WHOLE OR IN PART, FOR ANY PURPOSE OTHER THAN THAT FOR WHICH IT IS BEING MADE AVAILABLE WITHOUT THE EXPRESS ADVANCE WRITTEN PERMISSION OF A DULY AUTHORIZED AGENT OF THE COMPANY. THIS DOCUMENT IS THE PROPERTY OF THE AVERY DENNISON CO. AND IS TO BE RETURNED TO THE COMPANY ON DEMAND.

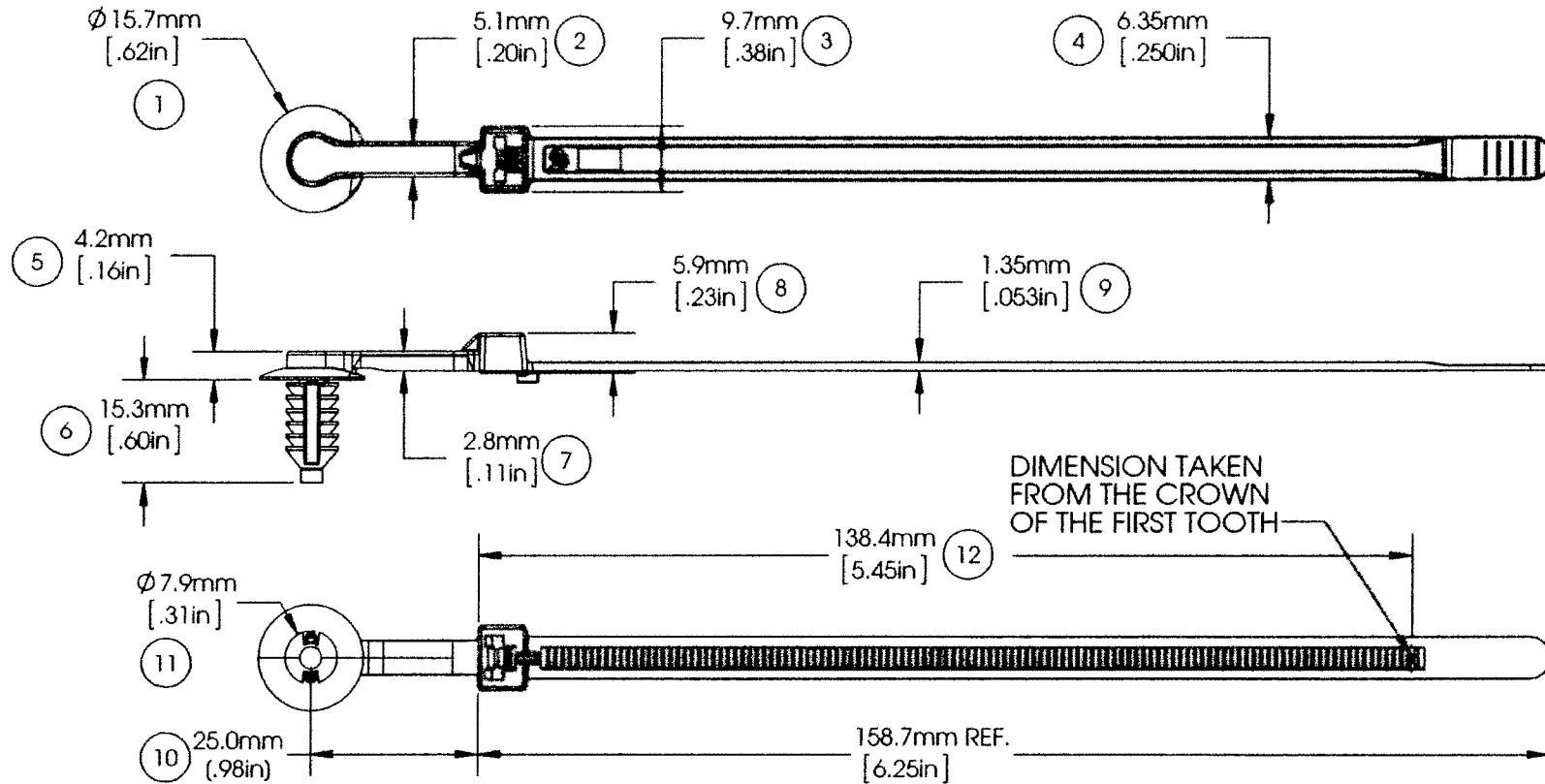

MOUNTING:	$\varnothing 6.60\text{MM} \pm 0.25\text{MM}$ HOLE AND 6.35MM HEX HOLE. PANEL THICKNESS OF 0.7MM TO 7.0MM .		
TENSILE STRENGTH:	50 LBF / 222.4N MIN.		
TEMPERATURE RANGE:	-40°F (-40°C) TO 239°F (115°C) CONTINUOUS AND 257°F (125°C) AT MAXIMUM EXPOSURE		
WEIGHT:	2.14 GRAMS EACH	APPROVALS: ENG. APPR. <i>[Signature]</i> 6-23-14 Q.A. APPR. <i>[Signature]</i> 6-23-14	AVERY DENNISON <small>FASTENER DIVISION FITCHBURG, MA 01420 U.S.A. TEL: 1-800-225-5913 FAX: 978-353-8157</small>
BUNDLE DIAMETER:	$\varnothing 1/16"$ (1.6MM) TO $\varnothing 1 - 1/2"$ (38.1MM)		
INSTALLATION TOOL:	12001 - HAND TOOL 12500 - PNEUMATIC TOOL	SPECIFIED TOLERANCES INCHES MM .XX \pm .03 .X \pm .7 .XXX \pm .01 .XX \pm .25 ANGULAR: $\pm 2^\circ$	MATERIAL NYLON 6/6, IMPACT MODIFIED, HEAT STABILIZED COLOR BLACK
TOOL TENSION SETTING:	6 - 8		DESCRIPTION 25MM LIFT OFFSET TIE - STD
PACKAGING:	1000/BAG, 5 BAGS/MASTER		STOCK NO. 20160-0 REV. A